



**Modular Cooking Range Line  
thermaline 90 - 4-Burner Gas Top with  
Ecoflam on Static Gas Oven, 1 Side,  
H=800**

ITEM # \_\_\_\_\_

MODEL # \_\_\_\_\_

NAME # \_\_\_\_\_

SIS # \_\_\_\_\_

AIA # \_\_\_\_\_



**589647 (MCQMFAJCPO)** 4-burner gas top on gas static oven, ecoflam, one-side operated

with or without ventilating mode.  
IPX5 water resistant certification.  
Configuration: Freestanding, One-side operated.

### Short Form Specification

**Item No.** \_\_\_\_\_

Unit constructed according to DIN 18860\_2 with 20 mm drop nose top and 70 mm recessed plinth. Internal frame for heavy duty sturdiness in 2 mm and 3 mm in 1.4301 (AISI 304). 2 mm top in 1.4301 (AISI 304). Flat surface construction, easily cleanable. THERMODUL connection system enables seamless worktop when units are connected and avoids soil penetrating. 4 gas burners with optimized combustion, flame failure device, thermocouple safety hand valve and protected pilot flame. Triple ring "flower" flame burners with anti-clogging design. Manual gas valves allow precise flame intensity control. Large pan support in cast iron with long center fins for various pan sizes. ECOFLAM pan detection system to save energy and to reduce unnecessary heat radiation in the kitchen. Deep flat spillage tray with rounded corners and drain hole. Metal knobs and oven handles with embedded hygienic silicon "soft" grip enable easier handling and cleaning.

Gas static oven chamber with 40 mm thick oven door and ribbed enamelled steel base plate. Oven chamber with 2 levels of runners for 2/1 GN shelves to enable simultaneous and faster cooking. Heavy duty thermostat with temperature range up to 300°C, electronic sensor for precise temperature control and manual humidity control in the cooking chamber. Upper heating element can also be used for grilling,

**APPROVAL:** \_\_\_\_\_



## Main Features

- Flame failure device on each burner protects against gas leakage when accidental extinguishing of the flame occurs.
- Large sized pan support in cast iron with long center fins to allow the use of the largest down to the smallest pans.
- Manual gas valves allow precise control of the flame intensity between high and low positions.
- Manual oven shut-off valve.
- Pans can easily be moved from one area to another without lifting.
- 40 mm thick oven door for heat insulation.
- All major components may be easily accessed from the front.
- THERMODUL connection system creates a seamless work top when units are connected to each other thus avoiding soil penetrating vital components and facilitating the removal of units in case of replacement or service.
- Metal knobs with embedded hygienic "soft-touch" grip for easier handling and cleaning. The special design of the controls prevents infiltration of liquids or soil into vital components.
- Oven chamber to have 2 levels of runners to accommodate 2/1 GN trays and ribbed enamelled steel base plate.
- The upper heating element of the oven can also be used for grilling.
- Manual control of humidity in cooking chamber.
- Electronic sensor for precise temperature control.
- Burners with optimized combustion. Triple ring flower flame burners with anti-clogging design.
- Deep flat spillage tray with rounded corners and drain hole to facilitate cleaning.
- 100% safety pilot and thermocouple.
- Oven temperature up to 300 °C
- Large visible digital display manufactured in tempered glass to resist heat and chemicals, showing temperatures or power settings. The display also shows on/off status of the appliance and on/off status of the heating elements.
- Patented Flower Flame burners that adjust to the size and form of the cookware (Patent EP2708813B1 and related family).

## Construction

- Each burner equipped with thermocouple safety hand valve and protected pilot flame.
- 2 mm top in 1.4301 (AISI 304).
- Unit constructed according to DIN 18860\_2 with 20 mm drop nose top and 70 mm recessed plinth.
- Flat surface construction with minimal hidden areas to easily clean all surfaces
- IPx4 water protection.
- Internal frame for heavy duty sturdiness in stainless steel.



### Included Accessories

- 1 of Grid, chromium plated, for ovens PNC 910652  
2/1 GN

### Optional Accessories

- Baking sheet 2/1 GN for ovens PNC 910651
- Bottom steel plate 2/1 GN for fire clay plate 800&900 with baking oven PNC 910655
- Fire clay plate 2/1 GN for ovens PNC 910656
- Connecting rail kit, 900mm PNC 912502
- Stainless steel side panel (12mm), 900x800mm, freestanding PNC 912511
- Portioning shelf, 1000mm width PNC 912528
- Portioning shelf, 1000mm width PNC 912558
- Folding shelf, 300x900mm PNC 912581
- Folding shelf, 400x900mm PNC 912582
- Fixed side shelf, 200x900mm PNC 912589
- Fixed side shelf, 300x900mm PNC 912590
- Fixed side shelf, 400x900mm PNC 912591
- Stainless steel front kicking strip, 1000mm width PNC 912600
- Stainless steel side kicking strips left and right, freestanding, 900mm width PNC 912621
- Stainless steel side kicking strips left and right, back-to-back, 1800mm width PNC 912627
- Stainless steel plinth, freestanding, 1000mm width PNC 912922
- Connecting rail kit, right PNC 912975
- Connecting rail kit, left PNC 912976
- Endrail kit, flush-fitting, left PNC 913111
- Endrail kit, flush-fitting, right PNC 913112
- Endrail kit (12mm) for thermaline 90 units, left PNC 913202
- Endrail kit (12mm) for thermaline 90 units, right PNC 913203
- Stainless steel side panel, left, H=800, flush PNC 913224
- Stainless steel side panel, left, H=800, flush PNC 913225
- T-connection rail for back to back installations without backsplash PNC 913227
- - NOT TRANSLATED - PNC 913232
- - NOT TRANSLATED - PNC 913251
- - NOT TRANSLATED - PNC 913252
- - NOT TRANSLATED - PNC 913255
- - NOT TRANSLATED - PNC 913256
- - NOT TRANSLATED - PNC 913259
- - NOT TRANSLATED - PNC 913277
- - NOT TRANSLATED - PNC 913278
- KIT LPG NOZZLES PNC 913292   
G30/30MBAR-4BUR+OVEN10KW
- STAINLESS STEEL DIVIDING PANEL 900X800MM LEFT/RIGHT PNC 913673
- STAINLESS STEEL SIDE COVER PANEL, FLUSH 900X800MM LEFT/RIGHT PNC 913689
- GAS MAINSWITCH FOR MODULAR H800 GAS UNITS (FACTORY FITTED) PNC 913698

Front

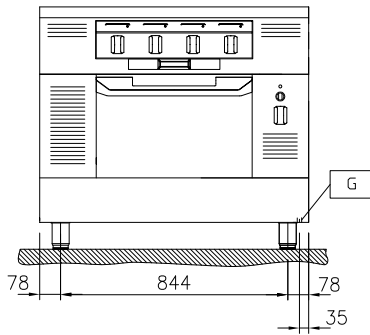

Side

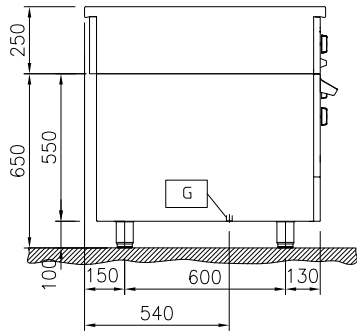

EQ = Equipotential screw  
 G = Gas connection

Top

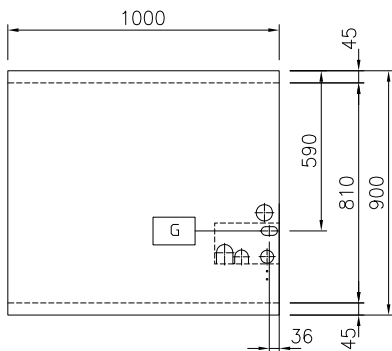
**Gas**

Gas Power:	47 kW
Gas Type Option:	
Gas Inlet:	1/2"

**Key Information:**

Oven working Temperature: 80 °C MIN; 300 °C MAX

Oven Cavity Dimensions (width): 683 mm

Oven Cavity Dimensions (height): 255 mm

Oven Cavity Dimensions (depth): 671 mm

External dimensions, Width: 1000 mm

External dimensions, Depth: 900 mm

External dimensions, Height: 800 mm

Net weight: 173 kg

**Configuration:**

On Oven; One-Side  
 Operated

Front Burners Power:

ISO 9001; ISO 14001 - ISO  
 9001; ISO 14001 kW

Back Burners Power:

10 - 10 kW

Back Burners Dimension -  
 mm

Ø 70 Ø 70

Front Burners Dimension -  
 mm

Ø 70 Ø 70